



AXRO MD 35/60

ELASTIC BINDER

CYKLOP[®]
GLOBAL PACKAGING SOLUTIONS

STRAPPING
WRAPPING
CODING
TAPING

The Axro MD 35/60 has the Axro binding techniques, which has for years been used in other Axro models. The Axro MD 35/60 is designed for strapping products with a maximum of 300 mm or 600 mm in depth. This machine can be used in multiple industries, including the copper and flower industry.

Advantages

- For elastic cord Cylastic PES, Cylastic PCs 1300, Cylastic 3K
- Can be integrated into automatic machine lines
- Robust and reliable
- Low maintenance
- Extremely easy operation
- Low noise
- Maximum throughput height is 150 mm
- Driven throughput with a depth of 350 mm (MD35) or 600 mm (MD60)
- Up to 60 cycles / minute



Opties

- Moveable, 4-wheel support frame (option)

[< CLICK HERE FOR A VIDEO OF THE MD 35/60 >](#)

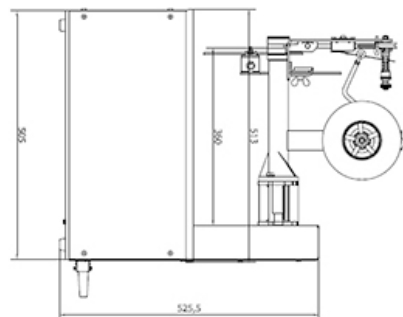
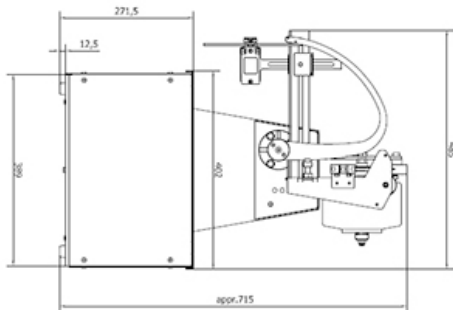

Technical Data	
Capacity	Up to 60 cycles/minute
Dimension (HxWxD)	925 x 390 x 820 mm
Input height	150 mm
Input depth	350 mm (MD35) or 600 mm (MD60)
Input	Left (standard), right optional
Tabletop	Stainless steel
Starter switch	Foot pedal, photocel, laser or PLC
String tension	Adjustable
Consumables	Cylastic PES, Pcs 1300, 3K
Power supply	230V, 110V, 50Hz, 1 ph
Weight	80 kg

Cyklop UK Limited
 Unit 2, Generation Business Park
 Barford Road
 St. Neots
 Cambridgeshire
 PE19 6YQ

+44 1480 216777
www.cyklop.co.uk
info@cyklop.co.uk

